

# SPECIFICATION

Customer : \_\_\_\_\_

Customer's Model No. : \_\_\_\_\_

Model No. : **MCR14 CCD Bar Code Scanning Module**

Date : \_\_\_\_\_

Sample Serial No. : \_\_\_\_\_

Spec. Version & Revision Date:      V02      2012.10.03

Received/Approved by

## TABLE OF CONTENTS

A. General Description.....	1
B. Physical Characteristics .....	2
C. MCR14 with Test Board Overview .....	3
D. Reference for control design.....	4
E. Electrical Characteristics .....	4
F. Performance .....	5
G. Environmental.....	5
H. Readable Symbologies.....	6
I. Decoder Data Output Connector .....	7
J. Trigger Command.....	8
K. Scan Map .....	8
L. Reliability .....	9

Due to SmartScan's continuing product improvement programs, specifications and features are subject to change without notice.

## A. General Description

The MCR Series brings the benefits of bar code scanning to a variety of OEM devices.

The MCR Series Scan Module is a perfect choice for your OEM design. The MCR Series brings the benefits of bar code scanning to all types of OEM devices. Now kiosks, medical instruments, diagnostic equipment, lottery terminals, vending machines and countless other appliances can all be equipped with the leading-edge scanning technology and reliability.

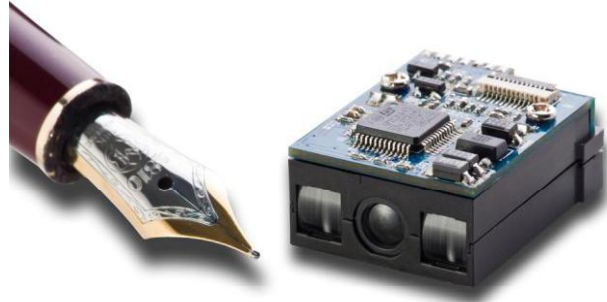

The MCR Series has been designed to provide the highest scanning performance in the smallest package possible. For added versatility, allowing for fast, cost-effective interchangeability when upgrading or modifying your OEM device for specialized applications.

**MCR14** is a miniature size and yet long-range CCD bar code scanning module with high sensitive liner image sensor. As operation under 100,000 LUX ambient light resistance, its cutting-edge smart detection technique design comes with up to 500 scans per second scan speed and up to 500mm reading distance, and aiding in various major bar codes, hand-on software-programming function, this MCR14 is your best choice of CCD type bar code scanning module to be suitable for application where needs a high performance and the reliable operation.

The Scanner module's miniature size makes MCR14 ideal for integration into data terminals and other small devices. The scanner module's unique open system architecture allows MCR14 to accept third party and custom plug-ins, giving the MCR14 virtually unlimited application flexibility.

## B. Physical Characteristics

Weight	
Body weight	Approx. 7g / 0.25oz (w/o test board)
Material	
	ABS+ Glass Reinforced Plastic
Connector	
	FPC 12pin Pitch 0.5
Dimension	
	20mm W x 11.5mm H x 25mm L

### Mechanical drawing

Unit : mm

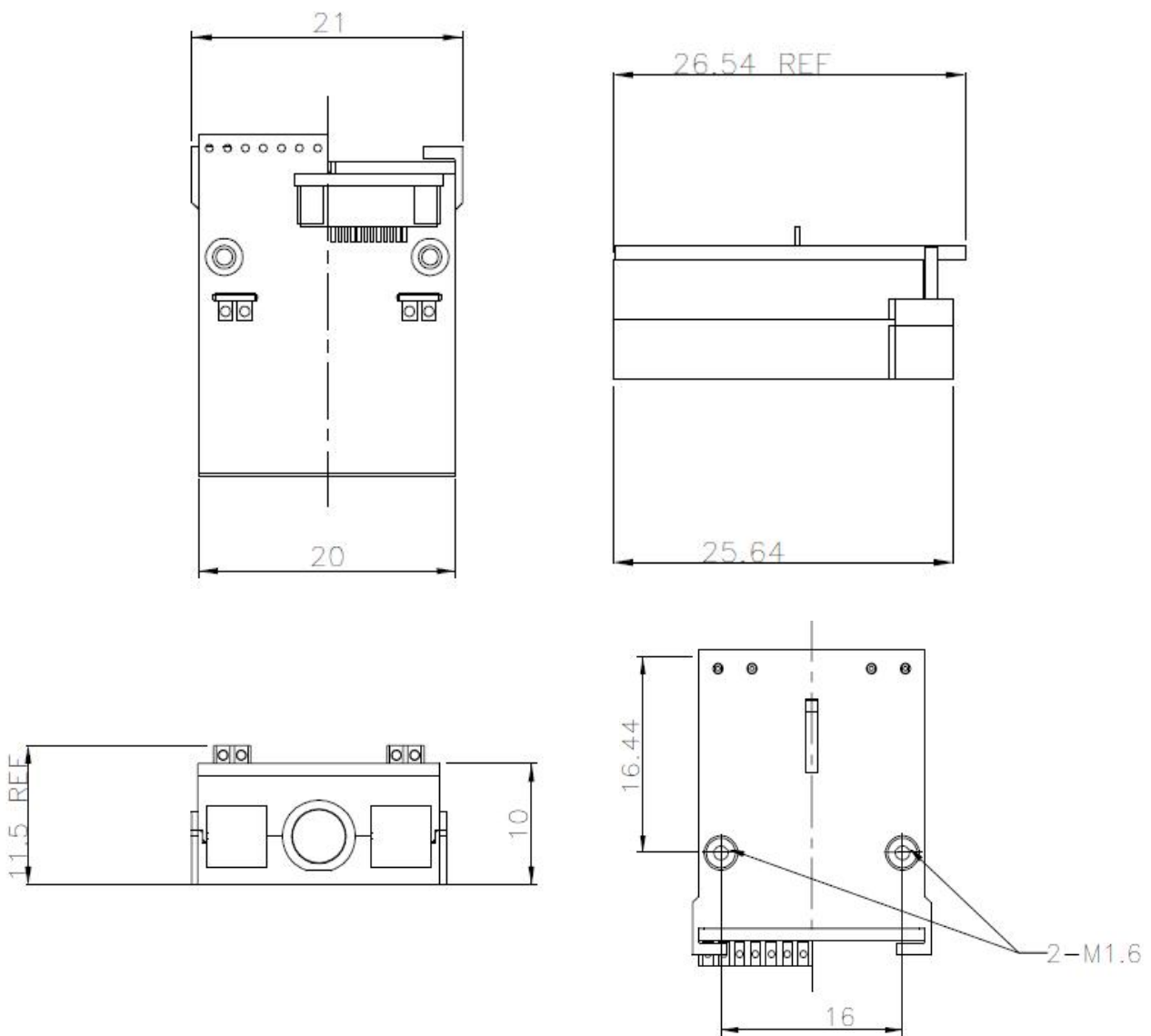

Unit : mm

## MCR14 CCD Bar Code Scanning Module

### Several combination options for choice,

1. MCR14 scan body only, have USB or UART interface as option,
2. MCR14 scan body with Test board, have RS232, USB or Keyboard interface as option.

### C. MCR14 with Test Board Overview

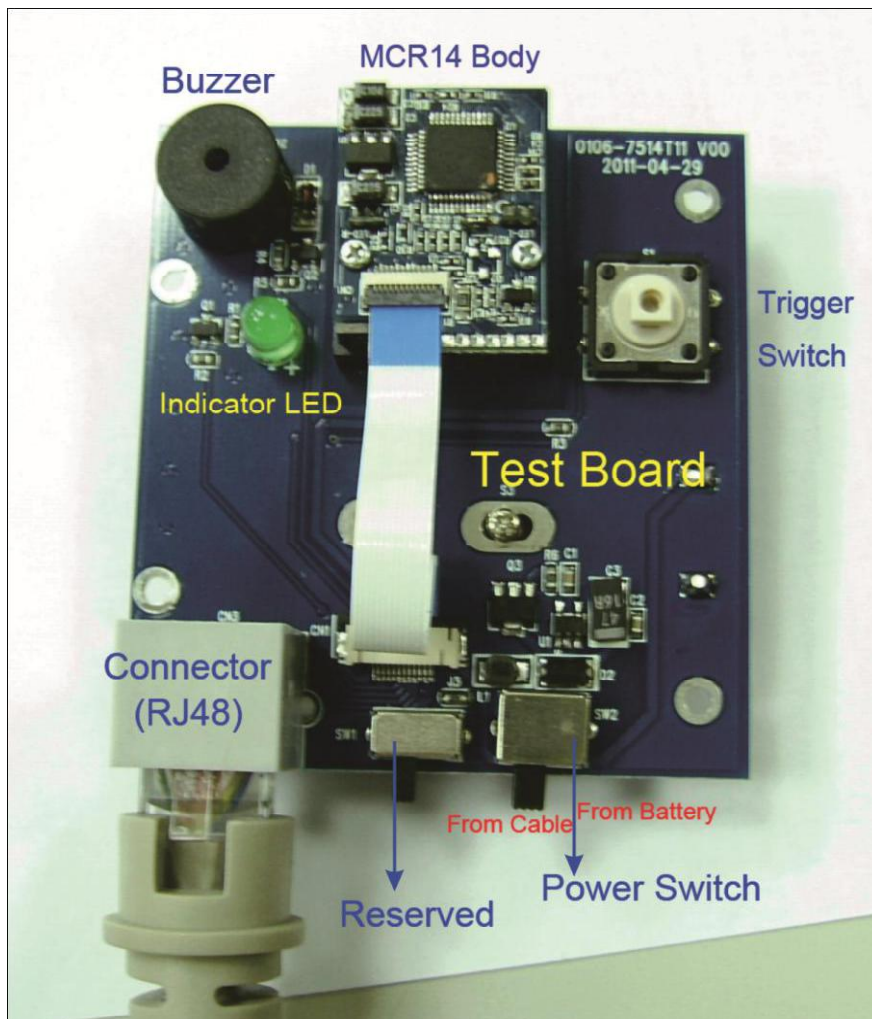

## MCR14 CCD Bar Code Scanning Module

### D. Reference for control design

The circuit from MCR14 test board is a reference for control design.

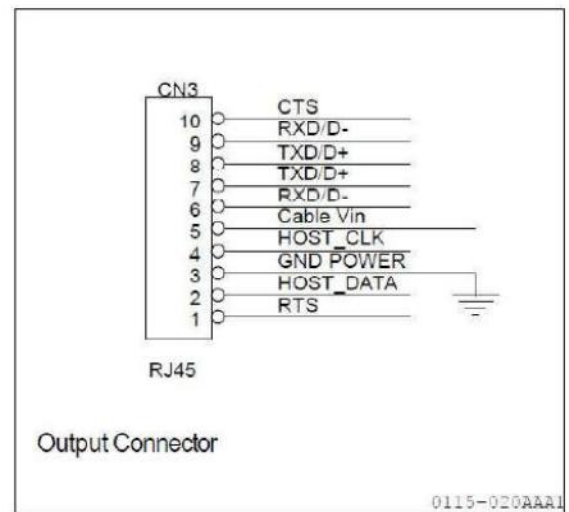
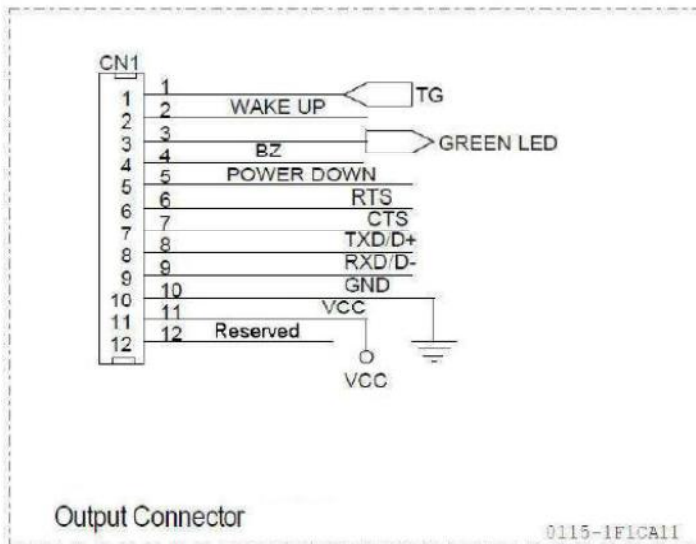
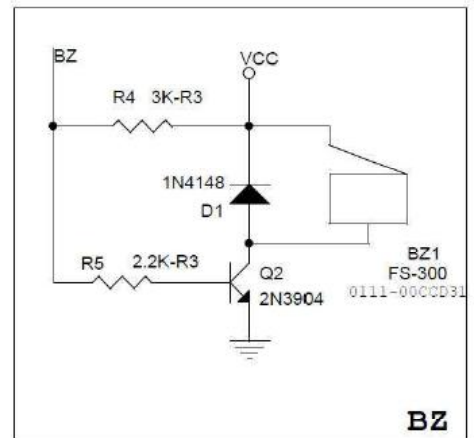
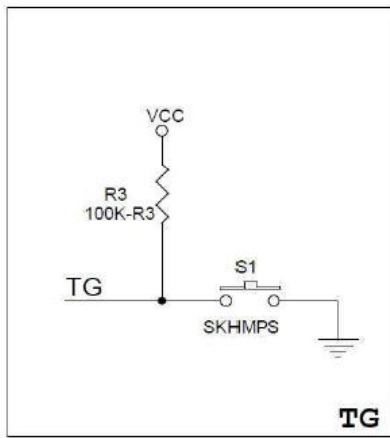
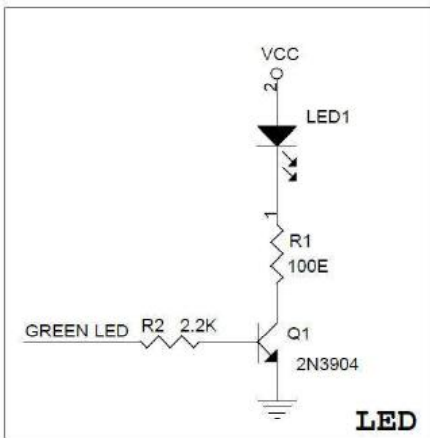

### E. Electrical Characteristics

Interface	RS232	KB	USB
Supply Voltage		DC +5V ±5%	
Output Voltage (Typ.)	±9V	+5V±5%	+5V±5%
Output low Voltage (Max.)		0.7V	
Current Draw		±10%	
Power On (Typ.)	170mA	170mA	170mA
Stand by (Typ.)	50mA	50mA	50mA
Operation (Typ.)	150mA	150mA	150mA

(Note: Calculated with test board)

## F. Performance

Light Source	Visible Red light 632nm LED
Sensor	Linear CCD Sensor
Processor Type	32-bit
Operating Freq.	8 MHz (Internal)
Scan Rate	Smart detection, up to 500 scans per second
Reading Distance	Up to 500mm@20mil/0.5mm, PCS90%
Print Contrast Ratio	30%
Resolution	4mil/0.1mm@PCS90%
Indicator	Beep

Reading Angle	<i>Test Conditions : Code 39, 10mil/0.25mm,PCS90%</i>
Pitch Angle	5°~60° (±5°)
Skew Tolerance	5°~60° (±5°)
Ambient Light	100,000 Lux Max.

## G. Environmental

Operating Temperature	0 °C to 50 °C (32 °F to 122 °F)
Storage Temperature	-20 °C to 70 °C (-4 °F to 158 °F)
Relative Humidity	20% to 95% (Non-condensing)

## H. Readable Symbologies

	Readable	Default Enable
All UPC/EAN/JAN	V	V
EAN128 Code	V	
Code 39	V	V
Code 39 Full ASCII	V	
Code32 / Italian Pharmacy	V	
Code 128	V	V
CODABAR/NW7	V	V
Interleave 25	V	V
Industrial 25	V	
Matrix 25	V	
MSI/PLESSEY	V	
Telepen	V	
Code 93	V	
Code 11	V	
China Postage	V	
Code 26	V	
LCD25	V	
GS1 DataBar Omnidirectional & Stacked	V	
GS1 DataBar Limited	V	
GS1 DataBar Expanded & Stacked	V	



## I. Decoder Data Output Connector

Type	FPC 12pin Pitch 0.5
Pin No.	Function
1	TG
2	AIM WAKEUP(Reserved)
3	GREEN LED
4	BZ
5	POWER DOWN(Reserved)
6	RTS
7	CTS
8	TXD (D+)
9	RXD (D-)
10	GND
11	VCC
12	Reserved

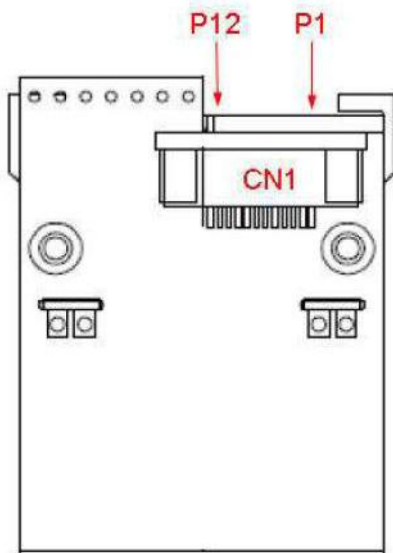

## J. Trigger Command

The RS-232 and USB Virtual COM command format for trigger is as following.

<STX> <TG> <ETX> <CHKSUM>

02 82 03 83 => HEX

Input 02820383 to trigger scanning.

The USB(HID) command format for trigger is as following.

CCCCC <STX> <TG> <ETX> <CHKSUM>

CCCCC 02 83 03 83 => HEX

Input CCCCC02830383 to trigger scanning.

## K. Scan Map

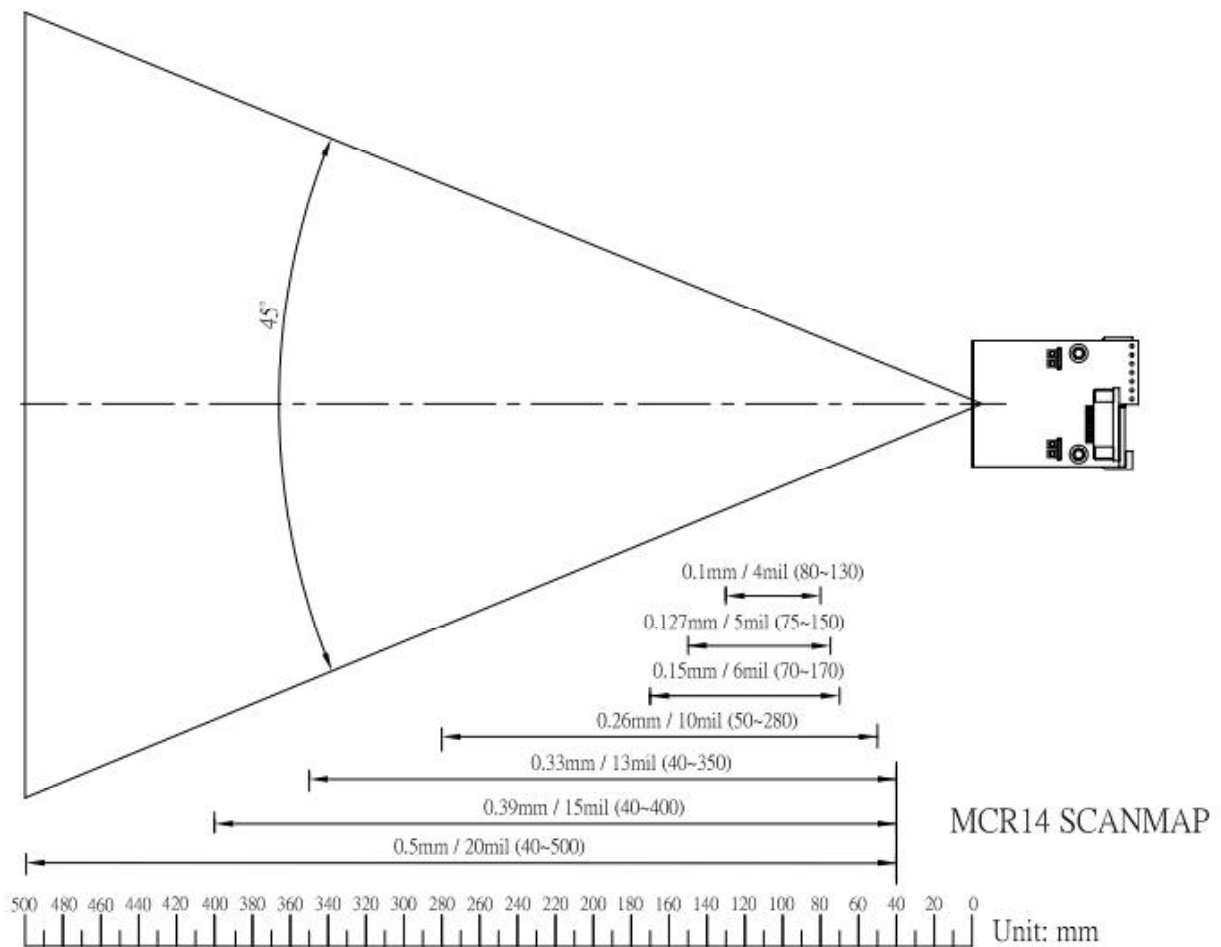

## L. Reliability

Life Time	
MTBF(Calculated)	50,000 hours
Thermal Shock	
High Temp.	60 °C (140 °F)
Low Temp.	-20 °C (-4 °F)
Cycle time	30 minutes for high temp. , 30 minutes for low temp.
Cycles	24 cycles
Mechanical Shock	2000G, 0.7ms, 3 axes